



# **AKAROA MKII**

## **Ultra-Low Emission Burner**

### **Installation & Operation Manual**

**Ash and Wood Stacker models**

**THIS MANUAL CONTAINS IMPORTANT INFORMATION.  
PLEASE KEEP IT IN A SAFE PLACE FOR FUTURE REFERENCE.**

**Manufactured in New Zealand by:**  
GLEN DIMPLEX NEW ZEALAND LIMITED  
P.O. Box 58473, Botany, Manukau - 2163  
Ph: 0800 666 2824  
Fax: 09 274 8472  
Email: [sales@glendimplex.co.nz](mailto:sales@glendimplex.co.nz)  
Web: [www.glendimplex.co.nz](http://www.glendimplex.co.nz)

Date: 14<sup>th</sup> MAR 2024

Part No. 599266

\*Glen Dimplex New Zealand Ltd reserves the right to change specifications, the content of this manual, or the design of its product without prior notice.

# **CONTENTS**

<b>Section</b>		<b>PAGE</b>
1	INTRODUCTION	3
2	ITEMS SUPPLIED WITH THE FIRE	3
3	HANDLING AND TRANSPORT	3
4	NOTES	4
4.1	CAUTIONS	4
5	TECHNICAL SPECIFICATIONS / SEIZMIC RESTRAINT	5
5.1	ALCOVE/RECESS INSTALLATION	6
5.3	REDUCING CLEARANCES	6
6	ASH HEARTH REQUIREMENTS	6
7	UNPACKING	6
8	POSITIONING	7
9	FLUE REQUIREMENTS	7
10	BRICK AND BAFFLE LAYOUT	7
11	FIRST BURN AND PAINT CURING	8
12	FUEL	8
12.1	WOOD MOISTURE	8
13.1	KINDLING INTERMEDIATE AND MAIN WOOD DETAIL	8
13.2	INITIAL LIGHT UP WITH KINDLING AND INTERMEDIATE LOAD	9
13.3	INTERMEDIATE LOAD 2 AND MAIN LOAD	9
13.4	CONTROLLING THE HEAT OUTPUT	9
13.5	REFUELING	9
14	ASH	10
15	OPTIMIZING THE BEST PERFORMANCE FROM YOUR HEATER	10
16	MAINTENANCE	10
17	REPLACEMENT PARTS	11
18	COMMON ISSUES AND PROBLEM SOLVING	12
19	FLUE TERMINATION REQUIREMENTS	13
20	WARRANTY TERMS AND CONDITIONS	14
21	FLUE SYSTEM INSTALLATION DIAGRAMS	16
22	WARRANTY REGISTRATION FORM	17

## **1. Introduction**

### **Congratulations!**

You are now the owner of a **MASPORT AKAROA MKII** Ultra-Low Emission Burner, designed and developed by Glen Dimplex New Zealand Ltd.

Firstly, thank you for purchasing a Masport Heating appliance.

Your new generation wood fire has been designed to provide you with all the warmth and comfort needed whilst having ULTRA LOW emissions to dramatically reduce the impact on the environment. Environment Canterbury has approved the installation of this burner throughout New Zealand, as it bears the MASPORT brand, it promises to provide you with economy, safety, efficiency and quality.

To make the most out of your appliance, installing, operating, and maintaining the burner correctly is important. Please read this installation and operations manual **carefully** before installing or operating your AKAROA MKII ULEB. Please take the time to understand the basic principles of this new burner which uses the latest combustion technology.

The bricks fitted in this burner are of a ceramic composition, they store invaluable heat to be released towards the end of the burn cycle while also reflecting heat into the ember bed creating a high combustion environment as well as increasing the radiant heat through the door glass. The baffle is made of stainless steel and supplies secondary air to aid the combustion process making for a cleaner hotter burn. This type of construction makes the heat durable and can reduce service costs in the long run.

## **2. Items supplied with the fire.**

- 1 x Masport ceiling plate
- 1 x St/St Main Baffle
- 3 x Ceramic Bricks
- 1 x Installation and Operation Manual which includes.
  - The Technical and Clearance Specification.
  - Installation guidelines
  - The Brick & Baffle Layout

## **3. Handling and Transport**

The AKAROA MKII appliance has a **Net weight of 115kg.**

Masport recommends that a minimum of 2 people handle the heater while moving it around and in positioning.

It is also recommended that suitable handling and safety equipment be used where applicable, removing items like the baffle, bricks and the door will help reduce the weight of the heater during the installation process.

Supplied in a wooden crate to reduce the risk of transport damage, if there is any visible damage to the crate, please inspect the heater and notify your retailer if there is any damage.

## **4. Notes**

- The installation of the AKAROA MKII ULEB requires building consent before installation commences. Check with your local Building Authority whether there are any additional requirements before installing.
- The burner and flue system shall be installed in accordance with AS/NZS 2918:2018 (2001) and the appropriate requirements of the relevant local building codes.
- Masport highly recommends NZHHA trained SFAIT (Solid Fuel Appliance Installation technician) installer to install your burner. Your dealer or heating specialist will be able to help with recommendations and advice on permits/consents required for the installation in your area.
- Please read carefully all the dimensions and recommendations provided in the technical

specification section of this manual. The dimensions given comply with the required safety standard AS/NZS 2918:2018 (2001).

- For safety, operational and warranty compliance, altering the appliance in any way, should not be attempted, no modifications are permissible.
- Please ensure that only components approved by Masport Heating New Zealand are used on the installation, as substitutes may adversely affect performance and might nullify compliance with the requirements of AS/NZS 2918 safety standards.
- The AKAROA MKII burner was tested using a Masport flue system, it is recommended that it is installed using a Masport flue system or a flue system that has been tested and complies with AS/NZS 2918:2018 (2001) Appendix F. All Masport burners have been tested using a Masport double flue shield and this must be used with your installation.
- Masport recommends that the flue system must be serviced annually by a NZHHA trained service agent.

#### **4.1 Cautions**

- This appliance is not intended for use by persons (including children) with reduced physical, sensory, or mental capabilities or lack of experience and knowledge unless they have been given supervision or instruction concerning the use of the appliance by a person responsible for their safety.
- Do not leave children unattended near the alighted fire and keep them well away from the fire when in use. Supervise young children to ensure that they do not play with the appliance.
- Do not use flammable liquids or aerosols to start or rekindle the fire. Also, do not use such flammable materials near this appliance when operating.
- Always keep clothing, firewood, furnishing, and other combustible materials at a safe distance from the fire.
- Do not touch any part of the fire other than the door handle and the air control when in use, as all other parts can be extremely hot.
- A Cracked/broken door glass makes the operation of the heater unsafe. Do not operate the fire with a cracked/broken door glass.
- Do not attempt to clean or maintain the fire when in use or with hot embers in the combustion chamber. Ensure that embers and all other parts of the fire have cooled down completely before starting ash removal or other maintenance.
- Do not use the fire if there is a malfunction, a suspicion of breakage, or unusual noises. Contact your Masport dealer or customer service team at Glen Dimplex, New Zealand.
- This appliance should always be operated and maintained as per instructions in this manual.
- The Ashpan should only be used once the heater is cool and safe to do so.

**Failure to follow above warnings, cautionary measures and instructions given in this Installation and Operation Manual will void the Masport Heating warranty of this product.**

## 5. Masport AKAROA MKII ULEB–Technical Specifications – ASH & WOOD STACKER

Approx. Heating Capacity	Small to Medium Homes (2-3 Bedrooms)
--------------------------	--------------------------------------

**AKAROA MKII burner model has been tested and complies with the following standards & tests:**  
**Environment Canterbury’s Real-life test** - Canterbury test method CM1  
**NZ National Environmental Test Standards** - AS/NZS 4012:2014 and AS/NZS 4013:2014.  
**NZ National Environmental Safety Test Standard** - AS/NZS 2918:2018 (2001)

<b>Overall Dimensions</b>	482mm Wide x 537mm Deep x 1039mm High				
<b>Net Weight of the Burner</b>	120 kg				
<b>Test Method</b>	<b>Average Max Heat Output</b>	<b>Emissions mg/MJ</b>	<b>Emissions g/kg</b>	<b>Efficiency %</b>	<b>Authorisation No</b>
<b>Real-Life Test Canterbury Method V1.6 (ULEB)</b>		31mg/MJ	-	-	CRC 242080 - Ash CRC 242078 - Wood Stacker
<b>National Environment Standard AS/NZS 4012/13:2014</b>	9kW	-	0.47g/kg	67%	CRC 242081 - Ash CRC 242079 - Wood Stacker

<b>Flue Shield</b>	600mm Long Masport SS Double Flue Shield
<b>Flue System</b>	Std 4.2M Long, 150mm Masport Flue System or Flue System that has been tested to and comply with AS/NZS 2918:2001 Appendix F ** For installation in Canterbury & South of Canterbury, we recommend extending 200 outer casings within 250~300 from flue termination. Also, we recommend not to use Masport Opti or equivalent flue kits in this area, as they take ceiling or external cold air and cool the flue casings, leading to accelerated creosote build-up in the main flue pipe.
<b>Floor Protector Requirement</b>	Ash Floor Protector
<b>Suitable Masport Steel Floor Protectors</b>	Parallel - 998908 & 998901 Corner - 998904

### Minimum Clearances to Combustibles and Floor Protector Dimensions: Parallel, Corner and Alcove configurations with a Minimum of 2.4m ceiling height

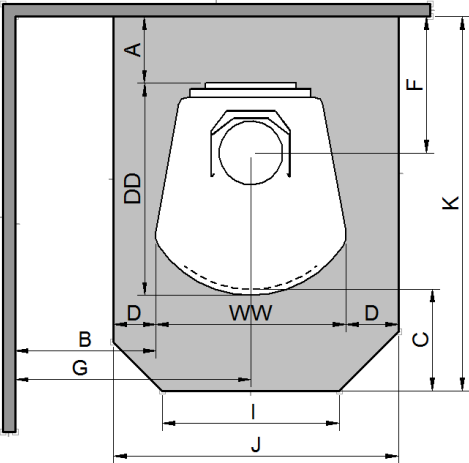
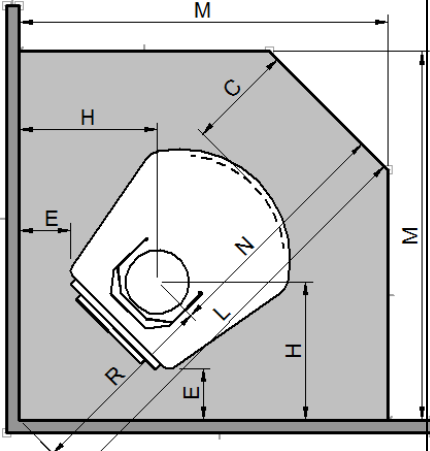
Parallel Installation		Corner Installation																																			
<table border="1"> <tr><td>A</td><td>93</td></tr> <tr><td>B</td><td>344</td></tr> <tr><td>C</td><td>300</td></tr> <tr><td>D</td><td>144</td></tr> <tr><td>F</td><td>271</td></tr> <tr><td>G</td><td>584</td></tr> <tr><td>I</td><td>470</td></tr> <tr><td>J</td><td>770</td></tr> <tr><td>K</td><td>920</td></tr> <tr><td>WW</td><td>482</td></tr> <tr><td>DD</td><td>537</td></tr> </table>  <p>C - Measurement taken from glass</p>	A	93	B	344	C	300	D	144	F	271	G	584	I	470	J	770	K	920	WW	482	DD	537	<table border="1"> <tr><td>C</td><td>300</td></tr> <tr><td>E</td><td>287</td></tr> <tr><td>H</td><td>507</td></tr> <tr><td>L</td><td>1390</td></tr> <tr><td>M</td><td>1180</td></tr> <tr><td>N</td><td>673</td></tr> <tr><td>R</td><td>717</td></tr> </table>  <p>C - Measurement taken from glass</p>	C	300	E	287	H	507	L	1390	M	1180	N	673	R	717
A	93																																				
B	344																																				
C	300																																				
D	144																																				
F	271																																				
G	584																																				
I	470																																				
J	770																																				
K	920																																				
WW	482																																				
DD	537																																				
C	300																																				
E	287																																				
H	507																																				
L	1390																																				
M	1180																																				
N	673																																				
R	717																																				

**Seismic Restraint** - In New Zealand, it is required that the wood burner and floor protector are secured to prevent shifting in the event of an earthquake. This is best done by fastening the wood burner right through the protector to the floor, using 8mm DynaBolts or 8mm coach screws or equivalent toggle fasteners for wooden floors of appropriate lengths. Seismic holes are at the rear of the burner.

## 5.1 Installation in Alcove/Recess situation

The AKAROA MKII Burner Models have been tested for Alcove (recess) made of combustible material and complied with the safety standards AS/NZS 2918:2018 (2001)

ALCOVE / RECESS WITH  
COMBUSTIBLE MATERIAL WALLS

C - Measurement taken from glass

**Note –**

- Refer to the Parallel Installation table on Page 5 for dimensions.
- The Ceiling height must be a minimum of 2400mm

A	93
B	390
C	300
F	271
G	631

**NOTE:** Any variation to the specified clearances must be done in accordance with AS/NZ 2918 Section 3

## 5.2 Reducing Clearances

The clearances to combustible specified in section 5.0 of this manual can be reduced by following guidelines specified in AS/NZS 2918:2018 (2001) table 3.1 & 3.2.

### Clearance factors for heat shield which is within 45 degrees of the vertical

Heat Shield Construction	Minimum Air Gap Dimension	Clearance Factor
Single layer of continuous material	12mm	0.4
Single layer of continuous material	25mm	0.3
Two spaced layers of continuous material	12mm+12mm	0.2

### Clearance factors for heat shield which is more than 45 degrees off the vertical

Heat Shield Construction	Minimum Air Gap Dimension	Clearance Factor
Single layer of continuous material	12mm	0.8
Single layer of continuous material	25mm	0.6

## 6. Ash Hearth Requirements

The AKAROA MKII has been tested and met the minimum requirement for an ash hearth set out in AS/NZS 2918:2018 (2001).

This heater weighs approximately 120kg so ensure that the floor structure is sufficient to withstand this weight, materials used for the floor protector must also be able to withstand the weight and not crack nor break.

## 7. Unpacking

Remove the shipping wooden crate and packing material around the burner. Remove the loose pieces from within the firebox. Remove and discard the screws holding the wood fire to the shipping pallet.

## 8. Positioning

Refer to minimum clearances in the above table. Note that the testing was carried out with a ceiling height of 2.4mtrs from the ground.

Any proposed deviation from the specified clearances or installation configurations should be in accordance with AS/NZ 2918:2018

## 9. Flue Requirements

A minimum 4.2m long, 150mm diameter Masport flue system or flue system tested in accordance with AS/NZS 2918:2018 (2001), Appendix F shall be used with a 600mm long Masport double skin flue shield.

It is highly recommended that the 200 inner casing of Masport flue system be extended to within 250~300mm below the top of the 250mm outer casing.

Please note that the environment may have an impact on how the flue system performs and may need additional components added to remedy these issues, flue casings other than standard height must be braced in accordance with relevant building codes.

Flue installations other than a standard vertical type are not recommended. However, if an installation requires offsets guidelines are set out with AS/NZS 2918:2018 (2001), it must be followed.

All flue pipe joints, and the flue spigot must be sealed using an appropriate fire cement, all flue pipes must be secured using 3x 3.25mm stainless steel rivets.

Be sure that flue pipes have been sealed as this can cause issues with the draw and a lack of performance from the heater.

## 10. Brick and Baffle Layout

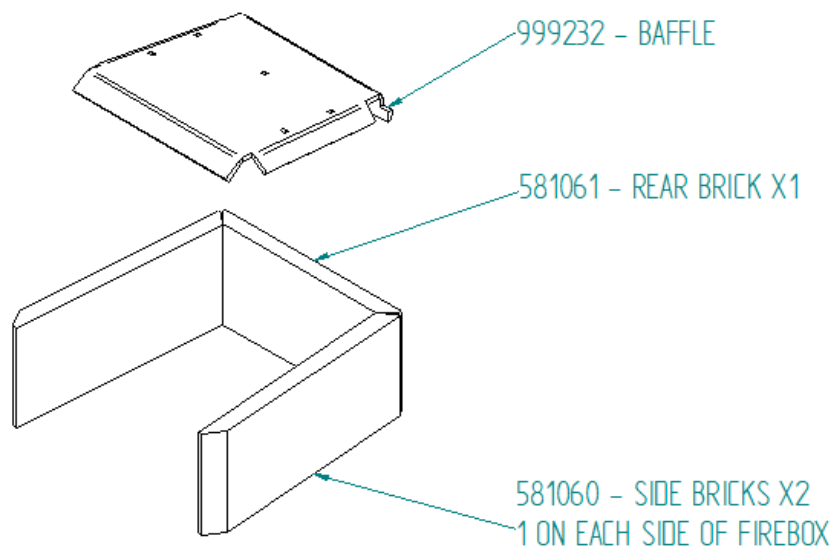

**Before the first light-up, ensure that the wood burner is correctly installed and signed off by an approved installer or local council. All local council's wood fire permit requirements have been completed satisfactorily and all components have been fitted to the heater.**

## 11. First burn & paint curing

Once your heater has been installed and meets the requirements of a consented installation you are ready to have your first burn. It is important to start off with a couple of small burns and not to over fuel the heater, this is because the paint will require curing. During this process, the paint will emit blue-ish coloured smoke, so it is important to have adequate ventilation during this process. Continue to run the heater until there is no more smoke, each burn can be progressively hotter until the curing process is completed.

## 12. Fuel

The quality of wood burnt can have a considerable effect on the performance of your wood burner. Moisture content, wood species and log size are the main factors affecting the performance of the burner. **Masport recommends the use of softwood** in the ULEB appliance, however, a combination of softwood and hardwood is also acceptable. A wood moisture range of 16-25% is ideal and a front-to-back loading orientation is advised. Following the above will give you a cleaner more efficient burning heater.

### **DO NOT BURN:**

- *Wood that has been treated with preservatives or impregnated with chemicals or glue.*
- *Chipboard, particleboard, or laminated board*
- *Painted, stained, or oiled.*
- *Driftwood or other salt-impregnated wood*

Burning such materials is not good for the environment, it can also damage the firebox and put you at the risk of voiding the warranty of your Masport heater.

In NZ, radiata pine or macrocarpa are the most commonly available softwood species suitable as firewood. Other hardwood species like eucalyptus (blue gum) can also be mixed with softwood to achieve longer burns.

### 12.1 Wood Moisture

A wood moisture meter is the best way to check the moisture content of the firewood. Split a piece of wood and then press the metering prongs firmly into the long side of a split piece to test moisture content. 16-25% percent of moisture content is ideal.

If you purchase firewood, ask for dry seasoned wood and get it checked from your wood merchant.

### 13.1 Kindling, intermediate and main wood loading details

Seasoned firewood pieces approx. 250mm long in various sizes should be used in the Masport AKAROA MKII.

- Kindling – 16 pieces cut to 1.0 kg approx.
- intermediate 1 load – 4 pieces total 1.2 kg, approx.
- intermediate 2 load – 4 pieces total 2.5 kg approx.
- main load – 3 pieces 3 kg approx.

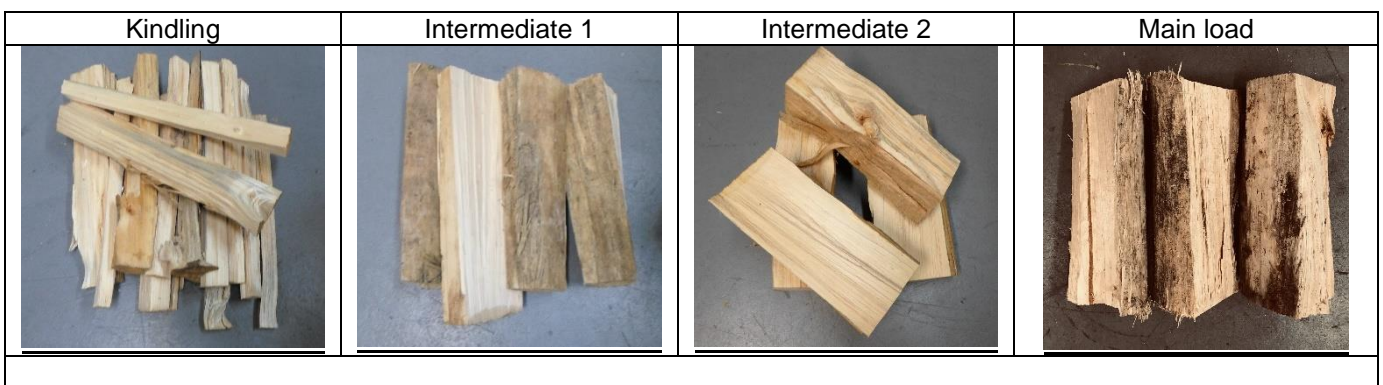



### **13.2 Initial light-up with kindling and intermediate load**

1. Make sure the air control is set in the "**HIGH**" position.
2. Place the intermediate load 1 evenly across the base of the heater in a front-to-back direction.
3. Place the kindling pieces on top of the 4 logs, they should be stacked 3x4x4 as in image 3.
4. Use 2 firelighters on the top of the kindling, one in the middle and one at the rear.
5. Light the rear fire lighter than the middle fire lighter, leave the door on the safety starter latch for approx 3 mins making sure the Kindling is well alight, now close the door.

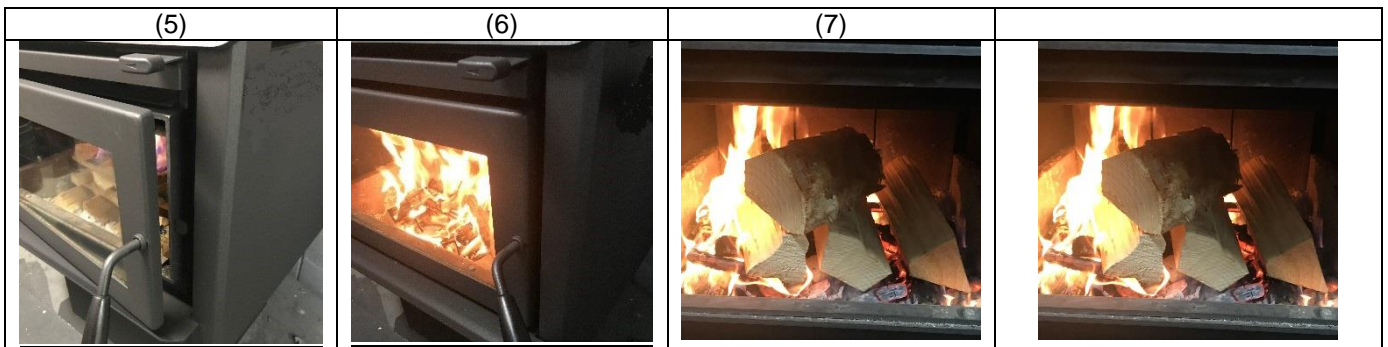

**Never leave the heater unattended during the startup phase and while the door is on the starter latch**

### **13.3 Intermediate load 2 and main loads**

6. Approximately 30 mins after lighting the heater Intermediate 2 can be loaded into fire.
7. Subsequent main loads should be loaded when the fuel in the heater has burnt down to good embers, and there is minimal flame in the heater.

### **13.4 Controlling the heat output.**

Once the main load has a well-established flame the air control can now be adjusted to a lower setting. Do not turn the air control directly from the high setting to low, adjust to approximately half setting wait for around 5-10 mins then adjust to the lowest setting.

Adjusting directly from high to low will starve the fire of oxygen and result in a poor burn.

### **13.5 Refueling**

Refueling is best done when most of the flame has died down and there is a good ember bed in the heater with minimal flame, always turn the heater air control to high and leave it there for a few minutes so the flue gasses can increase creating a good flue draught. Open the door slowly and not fast, this will stop any combustion gases from being pulled into the room.

Place your next main load into the heater as efficiently as you can and close the door as soon as possible, again this will reduce the risk of gases coming back into the room.

- IT IS IMPORTANT THAT THE HEATER IS NOT USED IF THE GLASS IS BROKEN
- DO NOT USE FLAMMABLE LIQUIDS OR AEROSOLS TO START OR REKINDLE THE BURNER
- DO NOT OPERATE THE HEATER IF EXCESSIVE SMOKE ENTERS THE ROOM

#### 14. Ash

Maintaining a good ash level will help the heater to operate more effectively, too much ash will reduce the usable volume within the heater and affect performance so ensure that the ash does not reach the level of the ash lip, always leave approx. 20mm of ash in the heater when cleaning the heater as this acts as an insulator and allows air to pass into the embers aiding the combustion process.

**Note** when emptying ash always do it when the heater is cold and always use a steel bucket, or the ash box on the ash model. Dispose of the ash **ONLY** when it is cold.

#### **ASHBOX**

The AKAROA MKII ash box is incorporated into the pedestal, to empty ash remove the ashplug from inside the firebox and proceed to push the ash into the cavity. Once you have removed sufficient ash, clean around the ash plug surface and reinsert it back into firebox. **IT IS IMPORTANT** to ensure the ash plug seat is clean to make sure there are no air leaks around it. Remove the ash box and dispose of the ash.

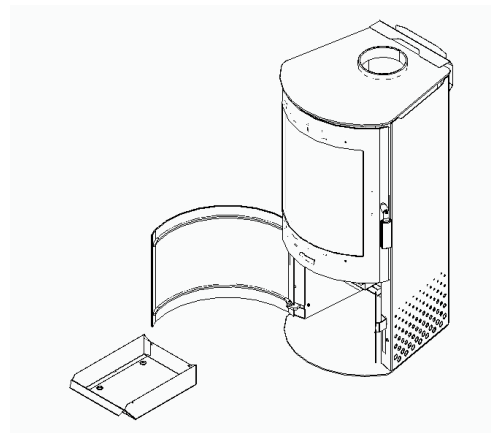
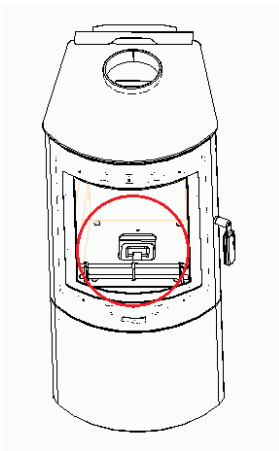

#### 15. Optimizing the best performance from your heater.

- Using clean dry wood will help with ignition and the combustion process.
- Maintaining a good hot ember bed at the start of each refueling will reduce pollutants and help with efficiency.
- Do not overfill the firebox as this will reduce air paths through the fuel and will not allow the heater to perform as intended.
- Using more medium-sized pieces of wood as opposed to very large pieces will give a better burn and will help keep the burn clean.
- Always open the air control to fully open position before refueling, do not run the heater on the low setting permanently, and after long periods on the low setting, it is recommended the heater is run on high to burn away any unwanted built-up of particulate within the heater and flue system.

#### NOTE

For the heater to perform optimally it must have a good air supply, in today's airtight homes this can be an issue, so it is advised that an adequate supply of fresh air is directed into the room that the heater is located in.

## **16. Maintenance**

### **Maintaining a clean glass**

Prolonged low burns, dirty wood and wet wood will cause the glass to blacken, this can be burnt off by running the heater on the high setting for a good period. Alternatively, when the heater is cold the glass can be cleaned by using damp newspaper and ash, glass cleaner and a ceramic glass-cleaning pad.

### **Cleaning the heater externally**

Using a soft **DRY** cloth or soft paintbrush, gently dust/wipe the painted surfaces. Under no circumstances use wet Cloths or chemical sprays on the paint, this may cause issues with the finish of your heater. Please note that the paint used on this heater will dull off over a period and can be touched up annually.

### **Door latch adjustment**

Open the main fuel loading door.

To adjust the tension on the door rope and have a good seal, the door catch pin can be moved forward and back, loosen the securing bolt on the inside of the firebox, move the pin toward the rear of the fire and re-tighten, repeat until a good seal has been achieved.

Testing the door seal while adjusting the spindle, Sandwich a strip of paper between the firebox edge and Seal, pull the paper gently and as you do there should be resistance on the paper, adjust the Spindle until you are satisfied a good seal has been made. The paper should be jammed or slide with effort when the seal is good or sufficient.

Carry out this test on all four sides of the door to ensure the seal is even on all sides.

### **Door and Door Glass Seals**

The main door seal should be checked periodically and if required will need to be replaced. Over time the door and glass seals will degrade and cause air to leak into the firebox. This excess air can affect the performance of the burner and possibly cause damage to the burner components. Air leaks can also cause blackening of the glass.

### **Heat Output Control (Air Slide)**

The air control on the burner should move freely, if at any time this becomes sticky have a service technician inspect and make the appropriate adjustments to free it up.

### **Firebox Ceramic Bricks**

The ceramic refractory bricks in your burner are an essential component for achieving a clean and efficient burn. These bricks may degrade/break or crack depending on usage, if cracks are visible but the brick is still secure then there is no need to replace them but if they degrade significantly or fall apart then they will require replacement. The bricks are held in place using the brackets welded to the firebox sides and the rear. see **section 10** (brick and baffle layout).

### **Baffle**

- The stainless-steel baffle used is made of Durable stainless steel, it has a rear air intake chute, which needs to be fitted properly into the slot on the back wall of the fire. For flue cleaning, this baffle must be removed as described below.
- First, pull forward the front baffle slightly to disengage the rear chute from the slot on the rear wall. Then push it to one side so that the baffle is off the other side's support. Keep dropping and tilting the other side to dislodge it entirely from the supports and then manoeuvre the baffle out of the firebox.
- For replacing the baffle, reverse the steps mentioned above.
- Check that the baffle is locked and hard up against the rear wall of the firebox.

### **Flue Inspection & Cleaning**

The flue system should be checked at least once a year and be swept by a professional chimney sweep. If a flue system is becoming excessively blocked or needs more frequent cleaning, investigate the installation, fuel, and operation of the burner with the help of a professional. First, remove all the ceramic bricks and the baffle. This will enable to drop and collect all the chimney dirt into the firebox without removing the main flue pipe. Once the chimney sweep operation is complete, clean the firebox chamber properly and replace the baffle then the bricks, both the air tubes and the bricks.

## **17. Replacement Parts**

Some components used in the AKAROA MKII are considered replaceable. These parts will wear out or degrade over time. The life of these parts will vary upon

- How frequently fire is used.
- Type of fuel.
- Moisture content in the wood
- Environmental effects

**The following items are considered operational consumable and hence replaceable items.**

- Bricks
- Baffle
- Front Air Deflector
- Seals - Main Door Seal and Door Glass Seal
- Door Glass

These replaceable parts should be replaced when it is deemed that they are no longer fit for purpose, running your burner with worn or broken parts may result in poor performance, an increase in fuel consumption, and even damage to the burner's firebox or other vital parts. We highly recommend a frequent visual inspection of these parts be carried out to determine whether replacement is required.

## **18. Common Issues and Problem Solving**

### **Blackening of the door glass –**

Blackening of the glass is due to poor combustion, reasons can be.

wet wood- heater being run on low setting for long periods- leaking door seals-incorrectly fitted components-poor flue draught-lack of combustion air.

Only burn dry wood with a moisture range of 16-25%.

Make sure to run the heater on high occasionally to burn off creosote buildup on the glass.

Have the door and glass seals checked and replaced as required.

Have the heater inspected to ensure the correct fitment of internal parts.

Have the heater installation checked for remedy reasons for lack of flue draught.

Remedy the reason for a lack of air in the room where the heater is situated.

### **Smoke entering the room –**

Smoke entering the room can be caused by several conditions, a lack of flue temperature, air starvation/negative pressure in the room, incorrect flue system/ terrain, pitch of the roof, staggered roofs, poor wood quality, installation issues and/or blocked flues.

Running the heater on a higher setting to increase the flue temperature especially when refuelling the heater.

Always make sure the room has an adequate air supply i.e., fresh air inlet, make sure there are no extractor fans running and or heat transfer kits.

Different flue terminations, extending the flue making sure there are no large trees around.

Make sure that the wood you are using has the correct moisture, is not too hard/dense and is not too resinous.

Have the installation checked and make sure that all flue joints are sealed, the correct flue lengths have been used, the flue termination is adequate, and all heater components are fitted.

Have the flue cleaned regularly, some situations may call for more frequent cleaning.

### **Paint –**

Paint fade, flaking and surface marks can be common issues with paint.

Paint fade is a normal process mostly seen in the hotter areas of the heater; this can be easily fixed at the end of the season with a touch-up using STOVE BRIGHT metallic black paint.

Flaking paint can be caused by using chemical sprays/cleaners or impurities in the paint.

Consult your local dealer to have this inspected.

Surface marks can mostly be resolved by touching up the heater with the use of STOVE BRIGHT metallic black paint.

Be sure to ONLY use a soft DRY cloth to clean your heater, the use of any other products May damage the paint on the heater.

NEVER use a wet or damp cloth to clean your heater.

**Noise general**

Expansion noises, environmental noises and excessive noises.

General expansion noise or ticking is a normal part of a wood heater and occurs during initial heating up and when the heater cools off.

Environmental noise is caused by wind passing over the flue system at an acceptable level, however, excessive noise i.e., load bangs and constant expansion noise can be the result of a poor installation, consult your local Masport representative to have this looked at in the first instance.

Noise created by environmental influences can be resolved by changes to the system in flue terminations.

**Performance issues**

This can be a result of installation issues, poor wood quality, where the heater is situated and environmental influences.

If you suspect your heater is not performing, contact your local MASPORT representative and have them examine all factors to try and resolve this issue.

**19. Flue Termination Requirements as per AS/NZS 2918:2001**

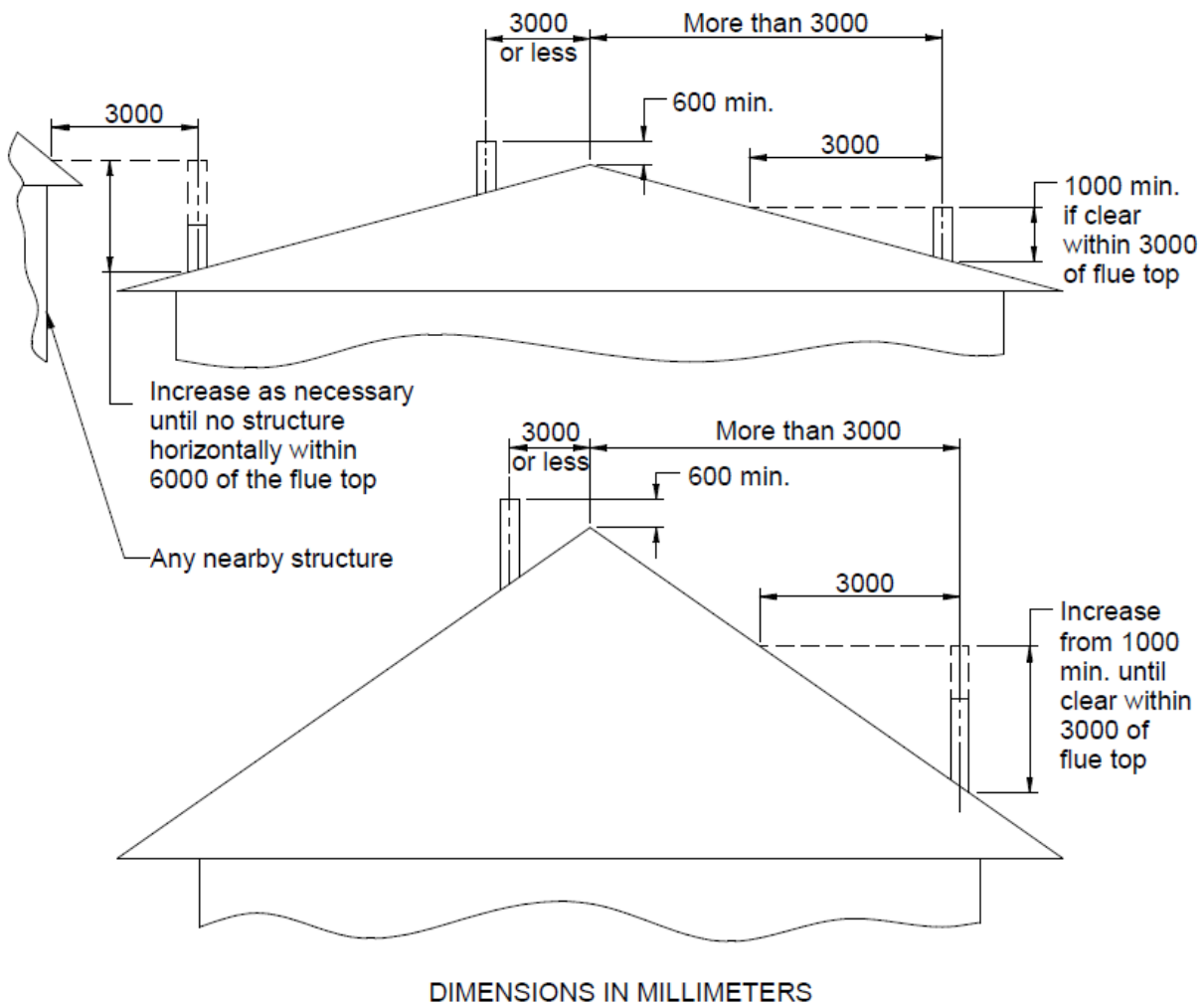

**FIGURE 4.8 MINIMUM HEIGHT OF FLUE SYSTEM EXIT**



## WARRANTY FOR MASPORT ULTRA-LOW EMISSION BURNER

**This warranty is provided in New Zealand by Glen Dimplex New Zealand Ltd and in Australia by Glen Dimplex Australia Pty Ltd. (together referred to as “Glen Dimplex”)**

This warranty is provided to the first domestic purchaser of a MASPORT AKAROA MKII Ultra-Low Emission Burner. It applies from the date of purchase, from or through an authorised Masport Fire Distributor in relation to each product or component for the period below.

TYPE OF PART	WARRANTY (In Years)	
	PARTS	LABOUR
BURNER'S STEEL FIRE BOX	15	5
STAINLESS STEEL BAFFLE	2	2
CERAMIC BRICKS	2	2
DOOR GLASS & SEAL	2	2
DOOR LOCKING MECHANISM PARTS	1	1
INTERNAL & EXTERNAL PAINT FINISH	1	1
GLEN DIMPLEX FLUE SYSTEM	1	1

During the warranty period, Glen Dimplex will repair or replace (at its option) any Masport Wood Fire which is found to be defective in materials or workmanship. Repairs will be carried out by an approved Masport Heating Service Agent.

### What is covered under this warranty?

- Repair or replacement of parts
- Labour costs relating to the Wood Burner
- Reasonable transport or travel costs.

**Consumers may have additional rights under the Consumer Guarantees Act 1993 (New Zealand) or the Australian Trade Practices Act 1974 including the Australian Consumer Law.**

### Conditions

This warranty does not apply and will be void where:

- The Wood Burner is not installed in accordance with AS/NZS 2918:2018 (2001) or any building code or consent.
- The Wood Burner is not installed by a qualified specialist installer.
- Any electrical work which has not been carried out by a Registered Electrician.
- The Wood Burner has been moved and reinstalled or has been modified in a manner that is not consistent with the Installation Guide or the Owner's Manual.
- The Wood Burner has not been installed, operated, or maintained according to the Installation and Operations Manual.
- The Wood Burner is used for business use in any way.

## **What is not covered under the terms of the warranty.**

- Wear and tear, including wear and tear through normal use on multi-fuel fire grates and cast-iron firebox liners.
- Labour costs relating exclusively to components not manufactured by Glen Dimplex.
- Damage caused by incorrect use or the burning of treated or painted wood, driftwood or other fuels which are not recommended.
- Travel costs for a distance greater than 50 km from the nearest approved Logaire Heating Service Agent. (The location of the Wood Fire must be advised to Glen Dimplex or its sales agents at the time of purchase or using warranty registration form)
- Defects, malfunctions, or failures caused by incorrect installation, poor installation, normal wear and tear, misuse, neglect, accidental damage, or failure to follow operating instructions in the Owner's Manual (including fuel selection, product operation and maintenance instructions), repairs or modifications by persons not authorised by Glen Dimplex, use of parts not supplied by Glen Dimplex, or damage or other events which have occurred since the product left the control of Glen Dimplex.
- Direct, indirect, or consequential losses or special damages of any kind (including costs of collection and delivery) other than repair or replacement of products or components under this warranty, where any goods are acquired or used for the purposes of a business.
- Performance issues due to site environmental conditions such as insufficient or excessive draught and down draft. Issues created due to such conditions are noise from the fire, and smoke spillage into the room.

## **How to obtain warranty service?**

- Completed Warranty registration form (previous page) needs to be mailed within 30 days of installation to your Glen Dimplex Warranty Registration Department.
- Warranty Claims must be made at the place of purchase.
- Reasonable proof of purchase date is required to make a warranty claim. You should keep your purchase receipt.
- Warranty repair will be completed according to the normal work practices of the service agent.
- Make the faulty part(s) available to Glen Dimplex for inspection so that the validity of the claim can be established by them.

### **Manufactured in New Zealand by:**

#### **GLEN DIMPLEX NEW ZEALAND LTD**

NZ Registration No – 1506305

P.O. Box 58473, Botany,

Manukau, Auckland 2163

Phone: 0800 666 2824

Fax: 09 274 8472

Email: [sales@glendimplex.co.nz](mailto:sales@glendimplex.co.nz)

Web: [www.glendimplex.co.nz](http://www.glendimplex.co.nz)

# **GLEN DIMPLEX WARRANTY REGISTRATION** **MASPORT AKAROA MKII ULTRA-LOW EMISSION BURNER**

Thank you for purchasing a Masport Fire. We ask you to complete the following information and return it to the Glen Dimplex Warranty Registration Department at the following address:

**New Zealand :** P O Box 58473, Botany, Manukau 2163, Auckland

Mr / Mrs / Miss / Ms

Name: \_\_\_\_\_

Address: \_\_\_\_\_

Post Code: \_\_\_\_\_

Telephone: \_\_\_\_\_ Fax: \_\_\_\_\_

Email \_\_\_\_\_

Model: \_\_\_\_\_ Serial Number: \_\_\_\_\_

Retailer: \_\_\_\_\_ Purchase Date: \_\_\_\_\_

Price: \_\_\_\_\_

Installed By: \_\_\_\_\_ Date Installed: \_\_\_\_\_

We at Glen Dimplex strive to provide you with quality products and have a continuous product development program. To help achieve our objectives to our mutual benefit we would welcome your feedback on the following questionnaire.

Question	Please tick appropriate remark			
1. General presentation of Product	<input type="checkbox"/> Excellent	<input type="checkbox"/> Good	<input type="checkbox"/> Ok	<input type="checkbox"/> Needs to Improve
2. Styling and Looks	<input type="checkbox"/> Excellent	<input type="checkbox"/> Good	<input type="checkbox"/> Ok	<input type="checkbox"/> Needs to Improve
3. Packaging	<input type="checkbox"/> Excellent	<input type="checkbox"/> Good	<input type="checkbox"/> Ok	<input type="checkbox"/> Needs to Improve
4. Is documentation easy to follow and informative?	<input type="checkbox"/> Excellent	<input type="checkbox"/> Good	<input type="checkbox"/> Ok	<input type="checkbox"/> Needs to Improve
5. Fixtures & Fittings (Loose parts)	<input type="checkbox"/> In order	<input type="checkbox"/> Items missing	<input type="checkbox"/> Needs to Improve	
6. Do you currently own Masport or Dimplex product?	<input type="checkbox"/> Yes	<input type="checkbox"/> No	Which? -	
7. Why did you decide on Masport? (Tick one or more options)	<input type="checkbox"/> Knew this brand		<input type="checkbox"/> Suggested by Friend	
	<input type="checkbox"/> Dealer recommended		<input type="checkbox"/> Better Price	
	<input type="checkbox"/> Performance		<input type="checkbox"/> Features	
8. Other Comments	_____			

**Privacy Act Notice:** the owner named on the Warranty Registration consents and agrees that Glen Dimplex may retain and use the information in this warranty card, including details about the owner for marketing and development purposes. The owner also agrees that Glen Dimplex may also share purposes with [intended recipients of such information]. In accordance with the New Zealand Privacy Act 1993 and the Australian Privacy Act 1988, the owner shall have the right to request the correction of, as well as inspect, all personal information held by Glen Dimplex on that owner.

**Please cut and mail this completed form within 30 days of installation to your  
Glen Dimplex Warranty Registration Department at the above address**